

PHYSICAL SPECIFICATION

Nominal Voltage		6V
Nominal Capacity (20HR)		4Ah
Dimension	Length	70±1mm (2.76 inches)
	Width	47±1mm (1.85 inches)
	Container Height	100±1mm (3.94 inches)
	Total Height	106±1mm (4.17 inches)
Weight		Approx. 0.67Kg ±3% (1.48lbs)
Standard Terminal		Fasten Tab No.187E (F1)

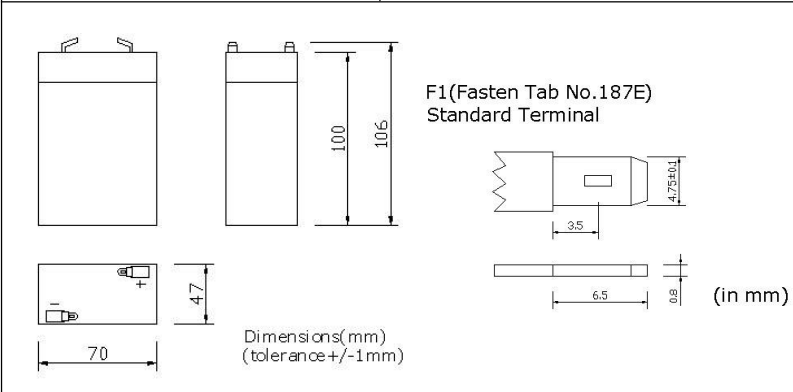
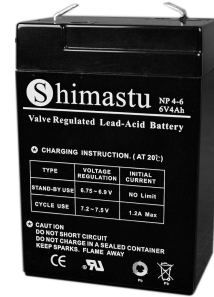

Shimastu NP series AGM VRLA Batteries have been developed as general purpose batteries, they're valve-regulated lead acid batteries with high quality Absorbed Glass Mat(AGM) separators & high purity raw materials, featured by perfectly good performance and reliable standby service life.

Features:

1. Non-spillable
2. Sealed and Maintenance-free Operation
3. High Quality and High Reliability
4. Less gassing, low Self-discharge
5. Low internal resistance
6. Long design life up to 6 years in float service at 25°C (77 °F)

ELECTRICAL SPECIFICATION

Characteristics		
Capacity	20 hour rate (0.2A)	4.0Ah
	10 hour rate (0.375A)	3.8Ah
	5 hour rate (0.68A)	3.4Ah
	3 hour rate (1.0A)	3.0Ah
	1 hour rate (2.2A)	2.2Ah
Capacity affected by temperature	40°C (104 °F)	102%
	25°C (77 °F)	100%
	0°C (32 °F)	85%
Max Discharge Current	40A(5 Sec)	
Short Circuit Current	210A	
Internal Resistance	Full charged battery (25°C, 77 °F) 25mΩ	
Constant Voltage Charge	Cycle	Initial Charging Current less than 1.2A Voltage 7.20~7.50V at 25°C (77 °F) Temperature Coefficient -15mV/°C
	Standby	No limit on Initial Charging Current Voltage 6.75~6.90V at 25°C (77 °F) Temperature Coefficient -10mV/°C

Discharge curves @ 25°C (77 °F)

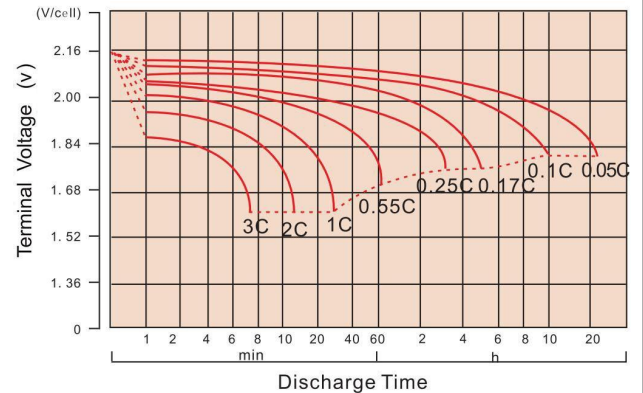

CONSTANT CURRENT DISCHARGE RATING A@25°C

F.V/TIME	5MIN	10MIN	15MIN	30MIN	1HR	3HR	5HR	10HR	20HR
1.60V	15.26	10.76	7.758	4.457	2.445	1.130	0.756	0.395	0.209
1.65V	14.19	10.16	7.418	4.279	2.361	1.095	0.737	0.390	0.206
1.70V	12.81	9.351	6.947	4.091	2.284	1.064	0.719	0.384	0.203
1.75V	11.49	8.562	6.465	3.910	2.200	1.032	0.700	0.380	0.200
1.80V	10.10	7.721	5.910	3.737	2.115	1.000	0.680	0.375	0.197

CONSTANT POWER DISCHARGE RATING WATT PER CELL@25°C

F.V/TIME	5MIN	10MIN	15MIN	30MIN	1HR	3HR	5HR	10HR	20HR
1.60V	25.29	18.28	13.55	8.096	4.593	2.157	1.455	0.776	0.411
1.65V	23.80	17.59	13.15	7.854	4.462	2.100	1.425	0.767	0.405
1.70V	21.97	16.49	12.50	7.585	4.343	2.050	1.395	0.756	0.401
1.75V	20.14	15.37	11.80	7.322	4.209	1.996	1.363	0.748	0.395
1.80V	18.08	14.11	10.94	7.069	4.070	1.942	1.329	0.740	0.390

Cycle service life



Trickle (or float) service life

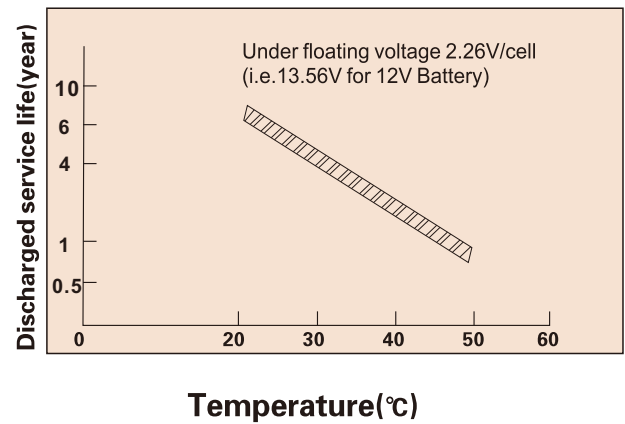

Storage time (months)



Temperature and discharge capacity

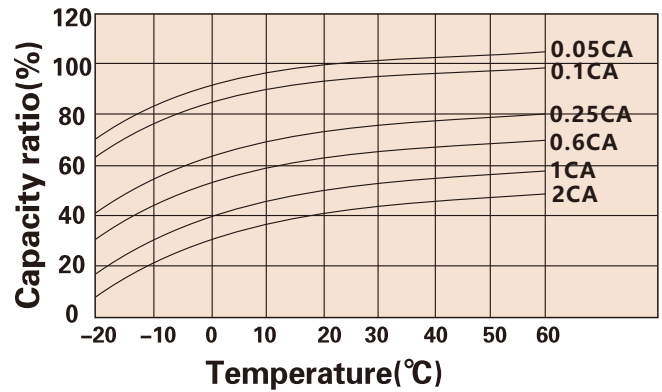

Charging characteristic

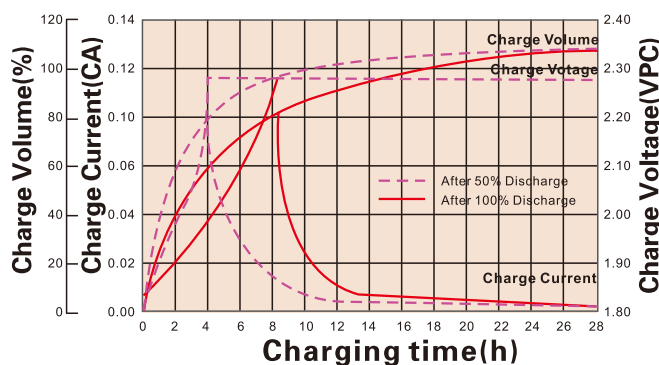

Storage Temperature	Supplementary Charge Interval	Charge Method
≤ 20°C	Every 12 months	Less or 24 hours with a constant voltage of 2.3V/cell
20-30°C	Every 8 months	12-18 hours with a constant voltage of 2.45V/cell
≥ 30°C	Storage to be avoided	8-12 hours with a constant current of 0.05CA

APPLICATIONS

Standby Usage:

- UPS
- Emergency Lights
- Alarm Systems
- Telecommunication Systems

Cyclic Usage:

- Medical Equipments
- Electric Instruments
- Toys
- Camcorder and Solar Systems

Motive Usage:

- Golf Cars
- Wheelchairs
- Lawnmowers
- Motorcycle

(Note) All above information shall be changed without prior notice, Shimastu reserves the right to explain and update the latest information.