

PHYSICAL SPECIFICATION

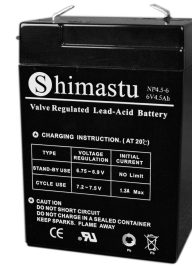

Nominal Voltage		6V
Nominal Capacity (20HR)		4.5Ah
Dimension	Length	70±1mm (2.76 inches)
	Width	47±1mm (1.85 inches)
	Container Height	100±1mm (3.94 inches)
	Total Height	105±1mm (4.13 inches)
Weight		Approx. 0.71Kg ±3% (1.56lbs)
Standard Terminal		Fasten Tab No.187E (F1)

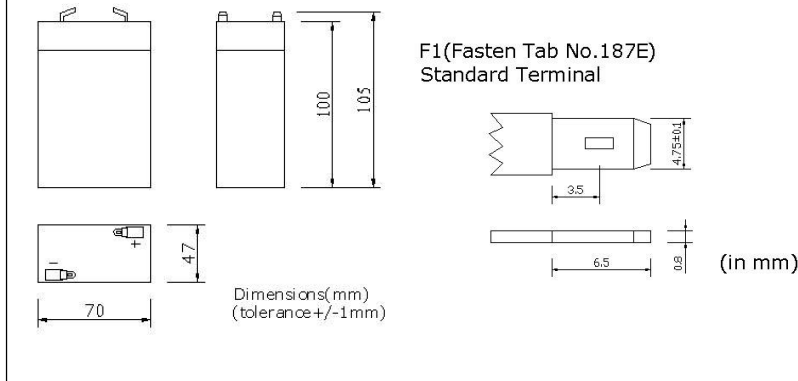

Shimastu NP series AGM VRLA Batteries have been developed as general purpose batteries, they're valve-regulated lead acid batteries with high quality Absorbed Glass Mat(AGM) separators & high purity raw materials, featured by perfectly good performance and reliable standby service life.

Features:

- 1.Non-spillable
- 2.Sealed and Maintenance-free Operation
- 3.High Quality and High Reliability
- 4.Less gassing,low Self-discharge
- 5.Low internal resistance
- 6.Long design life up to 6years in float service at 25°C (77 °F)

ELECTRICAL SPECIFICATION

Characteristics		
Capacity	20 hour rate	(0.225A) 4.5Ah
	10 hour rate	(0.423A) 4.2Ah
	5 hour rate	(0.765A) 3.8Ah
	3 hour rate	(1.125A) 3.4Ah
	1 hour rate	(2.475A) 2.5Ah
Capacity affected by temperature	40°C (104 °F)	102%
	25°C (77 °F)	100%
	0°C (32 °F)	85%
Max Discharge Current	45A(5 Sec)	
Short Circuit Current	234A	
Internal Resistance	Full charged battery (25°C,77 °F) 25mΩ	
Constant Voltage Charge	Cycle	Initial Charging Current less than 1.35A Voltage 7.20~7.50V at 25°C (77 °F) Temperature Coefficient -15mV/°C
	Standby	No limit on Initial Charging Current Voltage 6.75~6.90V at 25°C (77 °F) Temperature Coefficient -10mV/°C

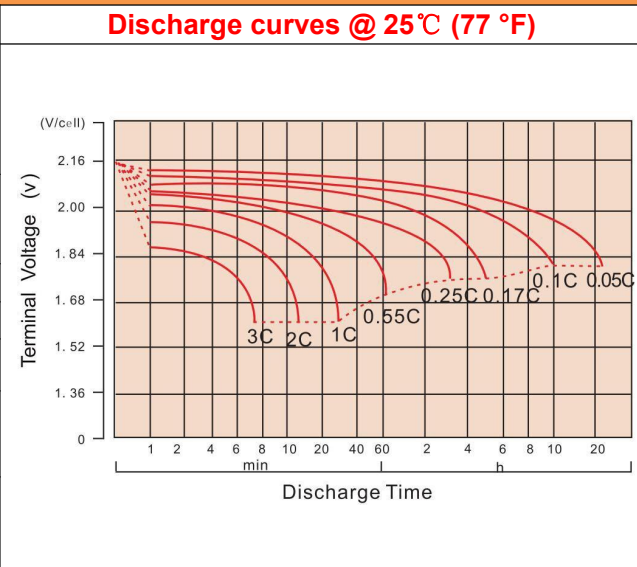

CONSTANT CURRENT DISCHARGE RATING A@25°C

F.V/TIME	5MIN	10MIN	15MIN	30MIN	1HR	3HR	5HR	10HR	20HR
1.60V	17.10	12.10	8.746	5.025	2.768	1.275	0.852	0.445	0.235
1.65V	15.93	11.46	8.365	4.825	2.675	1.238	0.831	0.440	0.232
1.70V	14.38	10.55	7.835	4.695	2.574	1.200	0.809	0.435	0.228
1.75V	12.87	9.612	7.292	4.409	2.475	1.163	0.787	0.428	0.225
1.80V	11.32	8.700	6.736	4.215	2.385	1.125	0.765	0.423	0.223

CONSTANT POWER DISCHARGE RATING WATT PER CELL@25°C

F.V/TIME	5MIN	10MIN	15MIN	30MIN	1HR	3HR	5HR	10HR	20HR
1.60V	28.350	20.560	15.290	9.127	5.202	2.435	1.641	0.874	0.463
1.65V	26.700	19.860	14.830	8.855	5.055	2.374	1.607	0.867	0.457
1.70V	24.650	18.600	14.100	8.703	4.894	2.312	1.571	0.856	0.450
1.75V	22.570	17.260	13.320	8.257	4.735	2.249	1.532	0.845	0.445
1.80V	20.260	15.900	12.470	7.973	4.589	2.185	1.495	0.834	0.441

Cycle service life



Trickle(or float) service life

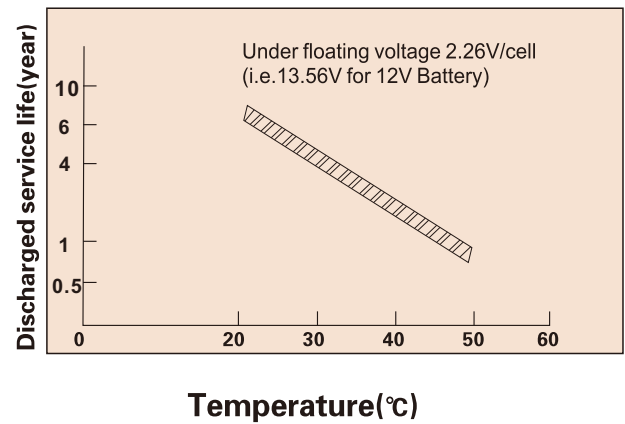

Storage time(months)

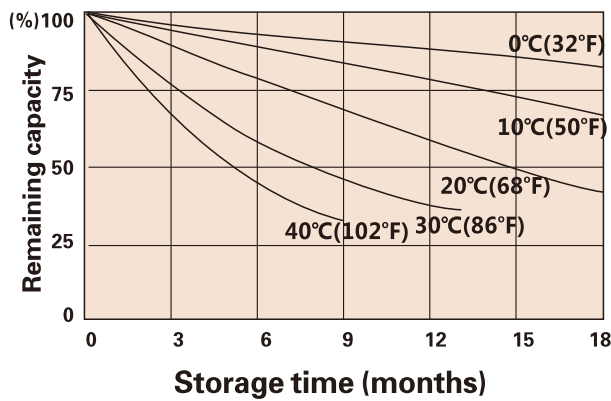

Temperature and discharge capacity

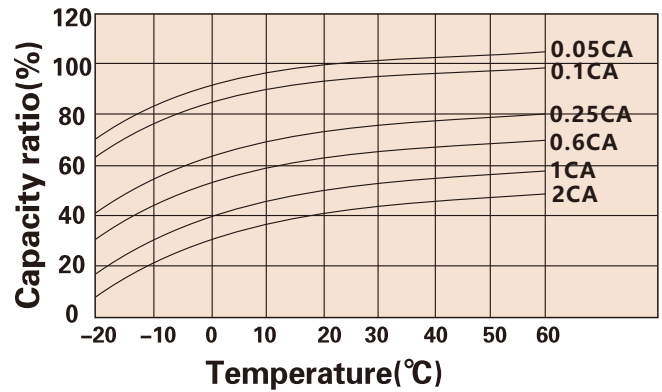

Charging characteristic



Storage Temperature	Supplementary Charge Interval	Charge Method
≤20°C	Every 12 months	Less or 24 hours with a constant voltage of 2.3V/cell
20-30°C	Every 8 months	12-18 hours with a constant voltage of 2.45V/cell
≥30°C	Storage to be avoided	8-12 hours with a constant current of 0.05CA

APPLICATIONS

Standby Usage:

- UPS
- Emergency Lights
- Alarm Systems
- Telecommunication Systems

Cyclic Usage:

- Medical Equipments
- Electric Instruments
- Toys
- Camcorder and Solar Systems

Motive Usage:

- Golf Cars
- Wheelchairs
- Lawnmowers
- Motorcycle

(Note) All above information shall be changed without prior notice, Shimastu reserves the right to explain and update the latest information.