

PHYSICAL SPECIFICATION

Nominal Voltage		8V	
Nominal Capacity (20HR)		3.2Ah	
Dimension	Length	68±1mm	(2.68 inches)
	Width	48±1mm	(1.89 inches)
	Container Height	90±1mm	(3.54 inches)
	Total Height	90±1mm	(3.54 inches)
Weight		Approx. 0.79 Kg ±3% (1.74lbs)	
Standard Terminal		Fasten Tab No.187E	

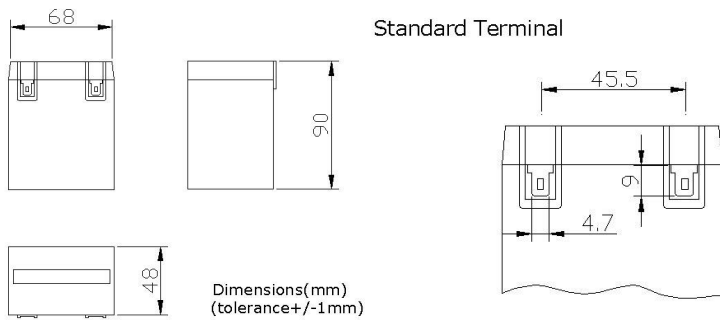

Shimastu NP series AGM VRLA Batteries have been developed as general purpose batteries, they're valve-regulated lead acid batteries with high quality Absorbed Glass Mat(AGM) separators & high purity raw materials, featured by perfectly good performance and reliable standby service life.

Features:

- 1.Non-spillable
- 2.Sealed and Maintenance-free Operation
- 3.High Quality and High Reliability
- 4.Less gassing,low Self-discharge
- 5.Low internal resistance
- 6.Long design life up to 6years in float service at 25°C (77 °F)

ELECTRICAL SPECIFICATION

Characteristics		
Capacity	20 hour rate	(0.16A) 3.2Ah
	10 hour rate	(0.30A) 3.0Ah
	5 hour rate	(0.544A) 2.8Ah
	3 hour rate	(0.8A) 2.4Ah
	1 hour rate	(1.76A) 1.8Ah
Capacity affected by temperature	40°C (104 °F)	102%
	25°C (77 °F)	100%
	0°C (32 °F)	85%
Max Discharge Current	32A(5 Sec)	
Short Circuit Current	165A	
Internal Resistance	Full charged battery (25°C,77 °F) 25mΩ	
Constant Voltage Charge	Cycle	Initial Charging Current less than 0.96A Voltage 9.6~10V at 25°C (77 °F) Temperature Coefficient -18mV/°C
	Standby	No limit on Initial Charging Current Voltage 9~9.2V at 25°C (77 °F) Temperature Coefficient -18mV/°C

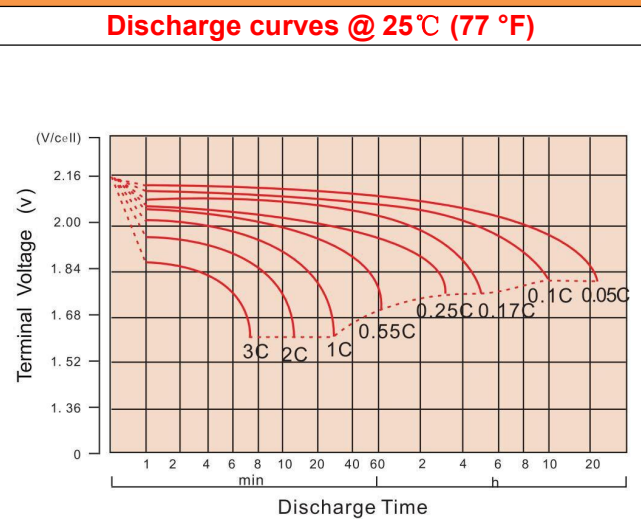

CONSTANT CURRENT DISCHARGE RATING A@25°C

F.V/TIME	5MIN	10MIN	15MIN	30MIN	1HR	3HR	5HR	10HR	20HR
1.60V	12.13	8.581	6.203	3.562	1.954	0.903	0.603	0.315	0.167
1.65V	11.29	8.108	5.930	3.419	1.888	0.874	0.588	0.313	0.165
1.70V	10.19	7.463	5.553	3.269	1.826	0.852	0.574	0.308	0.162
1.75V	9.131	6.833	5.169	3.124	1.760	0.825	0.559	0.303	0.160
1.80V	8.018	6.186	4.773	2.986	1.694	0.800	0.544	0.300	0.158

CONSTANT POWER DISCHARGE RATING WATT PER CELL@25°C

F.V/TIME	5MIN	10MIN	15MIN	30MIN	1HR	3HR	5HR	10HR	20HR
1.60V	20.10	14.58	10.84	6.471	3.675	1.723	1.164	0.620	0.327
1.65V	18.92	14.04	10.52	6.276	3.569	1.676	1.137	0.612	0.322
1.70V	17.47	13.17	10.00	6.060	3.473	1.639	1.112	0.605	0.320
1.75V	16.00	12.27	9.442	5.851	3.367	1.597	1.088	0.598	0.315
1.80V	14.35	11.30	8.841	5.649	3.256	1.553	1.063	0.590	0.312

Cycle service life

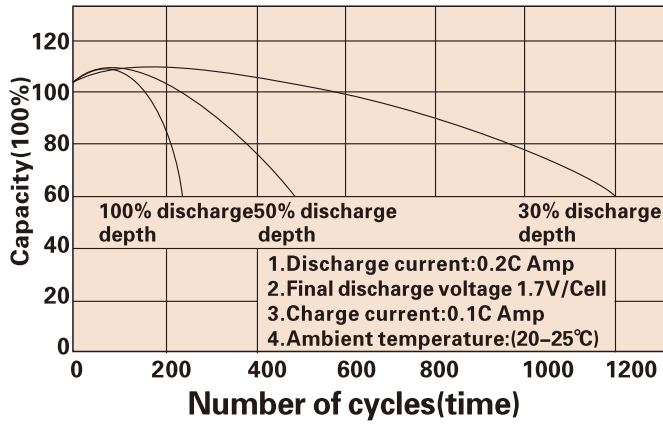

Trickle(or float) service life

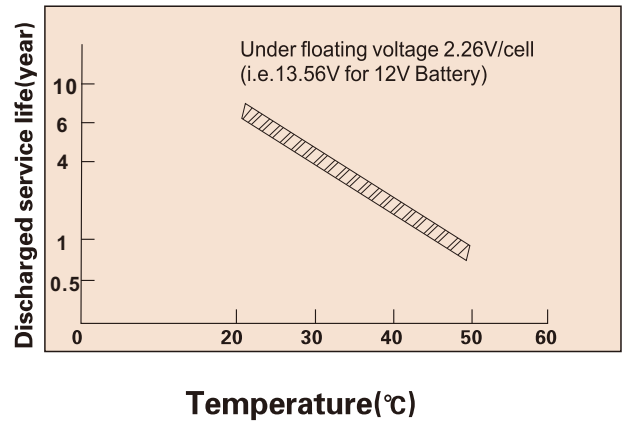

Storage time(months)



Temperature and discharge capacity

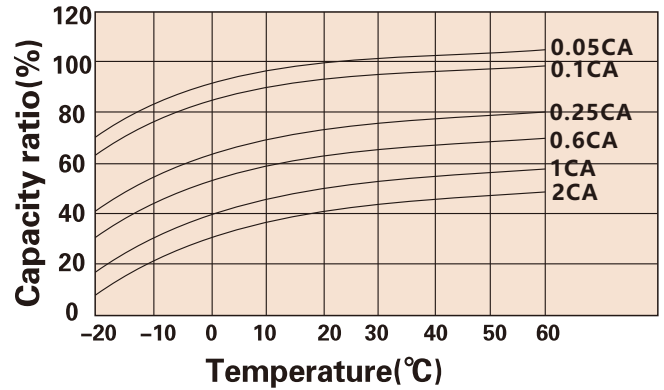

Charging characteristic



Storage Temperature	Supplementary Charge Interval	Charge Method
≤20°C	Every 12 months	Less or 24 hours with a constant voltage of 2.3V/cell
20-30°C	Every 8 months	12-18 hours with a constant voltage of 2.45V/cell
≥30°C	Storage to be avoided	8-12 hours with a constant current of 0.05CA

APPLICATIONS

Standby Usage:

- UPS
- Emergency Lights
- Alarm Systems
- Telecommunication Systems

Cyclic Usage:

- Medical Equipments
- Electric Instruments
- Toys
- Camcorder and Solar Systems

Motive Usage:

- Golf Cars
- Wheelchairs
- Lawnmowers
- Motorcycle

(Note) All above information shall be changed without prior notice, Shimastu reserves the right to explain and update the latest information.