

## PHYSICAL SPECIFICATION

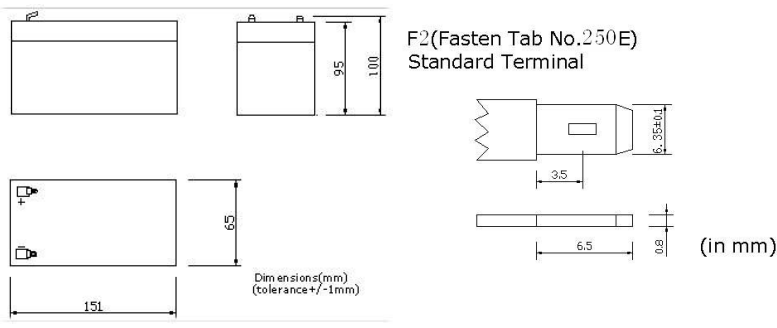

Nominal Voltage		12V
Nominal Capacity (20HR)		7.5Ah
Dimension	Length	151±1mm ( 5.94 inches)
	Width	65±1mm (2.56 inches)
	Container Height	95±1mm (3.74 inches)
	Total Height	100±1mm (3.94 inches)
Weight		Approx. 2.15 Kg ±3% ( 4.74lbs )
Standard Terminal		Fasten Tab No.250E(F2)



Shimastu NP series AGM VRLA Batteries have been developed as general purpose batteries, they're valve-regulated lead acid batteries with high quality Absorbed Glass Mat(AGM) separators & high purity raw materials, featured by perfectly good performance and reliable standby service life.

**Features:**

- 1.Non-spillable
- 2.Sealed and Maintenance-free Operation
- 3.High Quality and High Reliability
- 4.Less gassing,low Self-discharge
- 5.Low internal resistance
- 6.Long design life up to 6 years in float service at 25°C (77 °F)

## ELECTRICAL SPECIFICATION

Characteristics		
Capacity	20 hour rate (0.375A)	7.5Ah
	10 hour rate (0.705A)	7.1Ah
	5 hour rate (1.275A)	6.4Ah
	3 hour rate (1.875A)	5.6Ah
	1 hour rate (4.125A)	4.1Ah
Capacity affected by temperature	40°C ( 104 °F )	102%
	25°C ( 77 °F )	100%
	0°C ( 32 °F )	85%
Max Discharge Current	75A(5 Sec)	
Short Circuit Current	350A	
Internal Resistance	Full charged battery (25°C, 77 °F) 25mΩ	
Constant Voltage Charge	Cycle	Initial Charging Current less than 2.25A Voltage 14.4~15.0V at 25°C (77 °F ) Temperature Coefficient -30mV/°C
	Standby	No limit on Initial Charging Current Voltage 13.5~13.8V at 25°C (77 °F ) Temperature Coefficient -20mV/°C

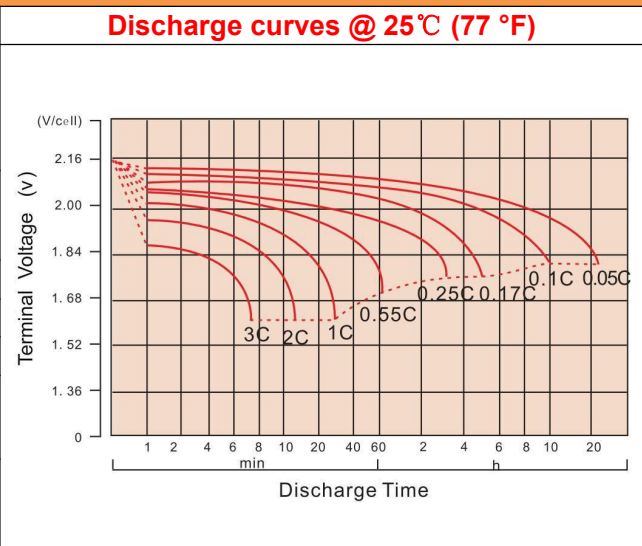

### CONSTANT CURRENT DISCHARGE RATING A@25°C

F.V/TIME	5MIN	10MIN	15MIN	30MIN	1HR	3HR	5HR	10HR	20HR
1.60V	28.74	20.31	14.68	8.433	4.612	2.124	1.419	0.741	0.391
1.65V	26.73	19.20	14.04	8.096	4.458	2.062	1.384	0.732	0.385
1.70V	24.11	17.67	13.15	7.738	4.290	1.999	1.347	0.724	0.379
1.75V	21.60	16.18	12.24	7.396	4.125	1.938	1.311	0.712	0.375
1.80V	18.97	14.64	11.30	7.069	3.975	1.875	1.275	0.705	0.370

### CONSTANT POWER DISCHARGE RATING WATT PER CELL@25°C

F.V/TIME	5MIN	10MIN	15MIN	30MIN	1HR	3HR	5HR	10HR	20HR
1.60V	47.65	34.51	25.67	15.32	8.669	4.057	2.734	1.455	0.771
1.65V	44.81	33.28	24.89	14.86	8.425	3.955	2.678	1.442	0.759
1.70V	41.34	31.17	23.67	14.35	8.157	3.853	2.617	1.427	0.749
1.75V	37.88	29.06	22.36	13.85	7.891	3.749	2.553	1.406	0.741
1.80V	33.97	26.76	20.93	13.37	7.649	3.641	2.491	1.391	0.732

### Cycle service life



### Trickle(or float) service life



### Storage time(months)



### Temperature and discharge capacity

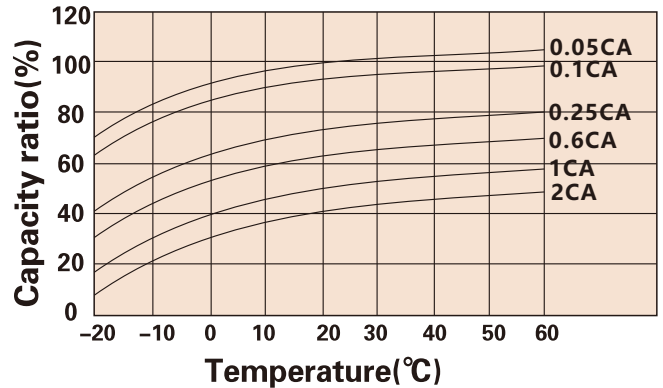

### Charging characteristic

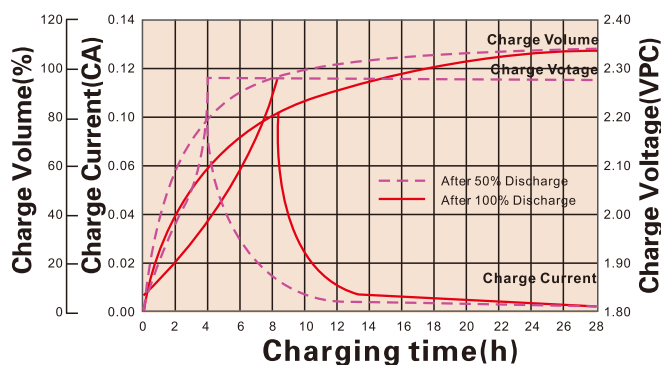

Storage Temperature	Supplementary Charge Interval	Charge Method
≤20°C	Every 12 months	Less or 24 hours with a constant voltage of 2.3V/cell
20-30°C	Every 8 months	12-18 hours with a constant voltage of 2.45V/cell
≥30°C	Storage to be avoided	8-12 hours with a constant current of 0.05CA

## APPLICATIONS

#### Standby Usage:

- UPS
- Emergency Lights
- Alarm Systems
- Telecommunication Systems

#### Cyclic Usage:

- Medical Equipments
- Electric Instruments
- Toys
- Camcorder and Solar Systems

#### Motive Usage:

- Golf Cars
- Wheelchairs
- Lawnmowers
- Motorcycle

(Note) All above information shall be changed without prior notice, Shimastu reserves the right to explain and update the latest information.